



# SPRINT 15

## Owner's Manual

—

Windsport International  
Mylor Harbour  
Falmouth, Cornwall  
TR11 5UF, UK  
+44 (0) 1326 376191  
[info@windsport.co.uk](mailto:info@windsport.co.uk)  
[www.windsport.co.uk](http://www.windsport.co.uk)



# RIGGING MANUAL





# RIGGING MANUAL – SPRINT 15

The Sprint 15 rigging instructions are a comprehensive guide to rigging your SPRINT 15. Due to production supplies certain parts may be slightly modified from those shown.

This instruction manual is not a guide to sailing your craft and should not be considered as suitable for the purpose of learning to sail a catamaran. Windsport recommend

“The Catamaran Book” by Tom & Brian Phipps.

For additional help contact WINDSPORT INTERNATIONAL : Tel: +44 (0)1326 376191 or [info@windsport.co.uk](mailto:info@windsport.co.uk)

For replacement parts service and regional Dart Partner network visit:  
[www.catparts.windsport.co.uk](http://www.catparts.windsport.co.uk)

## **Windsport & Coastland (Catamaran Sailing Tuition)**

The WINDSPORT is the only recommended catamaran sailing school, using a full range of up-to-date catamarans and highly trained and experienced instructors : tuition is offered from Beginner to Squad/Championship coaching.

More details from WINDSPORT INTERNATIONAL : Tel: +44 (0)1326 376191 or [info@windsport.co.uk](mailto:info@windsport.co.uk) <https://www.coastland.life>

## **CONTENTS**

<b>Glossary</b>	<b>2</b>
<b>Rigging Instructions</b>	<b>3</b>
<b>Accessories</b>	<b>15</b>
<b>General Maintenance</b>	<b>16</b>
<b>Basic Safety Afloat</b>	<b>17</b>
<b>Option Attachment Dimensions</b>	<b>18</b>

## GLOSSARY

<b>AFT</b>	Towards the back of the boat	<b>MAST HEEL</b>	Casting at base of mast
<b>BATTEN</b>	Plastic strip put into the sail	<b>PORT</b>	Left-hand side of craft looking forward
<b>BOW</b>	Front of the boat	<b>SHACKLE</b>	U-shaped piece of metal secured with a Pin, used for securing halyards to sails etc
<b>BURGEE</b>	Flag flown from top of mast	<b>SHROUD</b>	Wire securing mast in position and preventing it from falling sideways
<b>BRIDLE WIRE</b>	Connecting bow to forestay	<b>STARBOARD</b>	Right-hand side of craft looking forward
<b>CLEW</b>	Lower back end of sail	<b>STERN</b>	Aft-most area of boat
<b>FOOT</b>	Bottom edge of sail	<b>TACK</b>	Lower forward corner of sail
<b>FORWARD</b>	Towards the boat front	<b>TILLER</b>	Length of aluminium which fits into the rudder head to allow steerage
<b>FORESTAY</b>	Front wire supporting mast	<b>TILLER EXTENSION</b>	Length of aluminium connected to the tiller by a universal joint which allows steerage whilst leaning out
<b>GUNWHALE</b>	Outer edge of boat	<b>TRAPEZE WIRE</b>	Wire used to extend the body beyond gunwhale of boat
<b>HALYARD</b>	Rope or wire used to hoist/lower sails	<b>TRANSOM</b>	Flat area across the back of boat to which the rudder is hung
<b>HEAD</b>	Top corner of sail	<b>WINDWARD</b>	Side of boat opposite to which the mainsail is set when sailing
<b>HOUNDS</b>	Connecting point for wires		
<b>JIB SHEET</b>	Rope used to control position of jib when under sail		
<b>LEECH</b>	Trailing edge of sail		
<b>LEEWARD</b>	Side of boat on which the mainsail is set when sailing		
<b>LUFF</b>	Front edge of sail		
<b>MAIN SHEET</b>	Rope controlling the position of main sail		

- 1 Bow
- 2 Stern
- 3 Port Hull
- 4 Stbd Hull
- 5 Mast
- 6 Burgee
- 7 Forestay
- 8 Bridle Wires
- 9 Port shroud
- 10 Stbd shroud
- 11 Mainsail
- 12 Jib
- 13 Battens x 9
- 14 Main beam
- 15 Rear beam
- 16 Port rudder
- 17 Stbd tiller arm
- 18 Connecting Bar
- 19 Tiller extension
- 20 Main sheet
- 21 Jib sheet
- 22 Downwind indicator

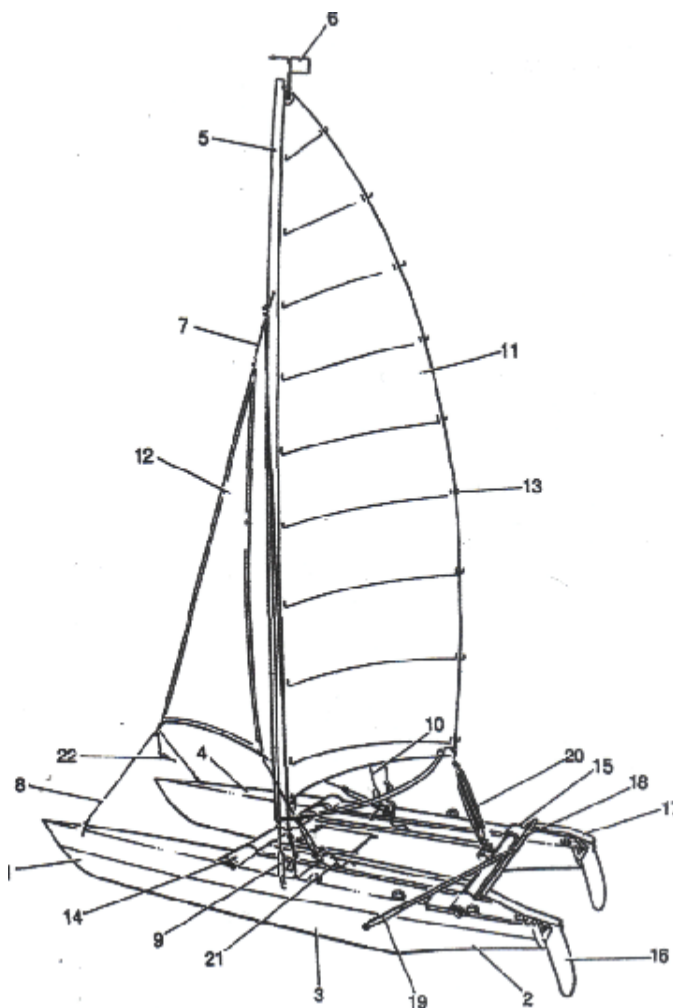

# RIGGING YOUR SPRINT 15

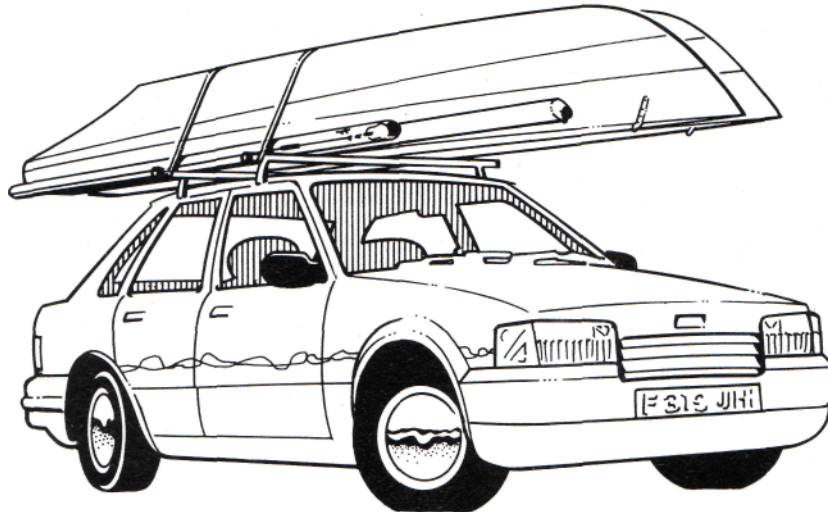

## REMOVING CATAMARAN FROM CAR ROOF

Remove all securing straps.  
 Lift each hull and place on the ground.  
 Remove spars, sails and other equipment.  
 Lay out all parts of the boat and identify with the contents list. (Fig 1)

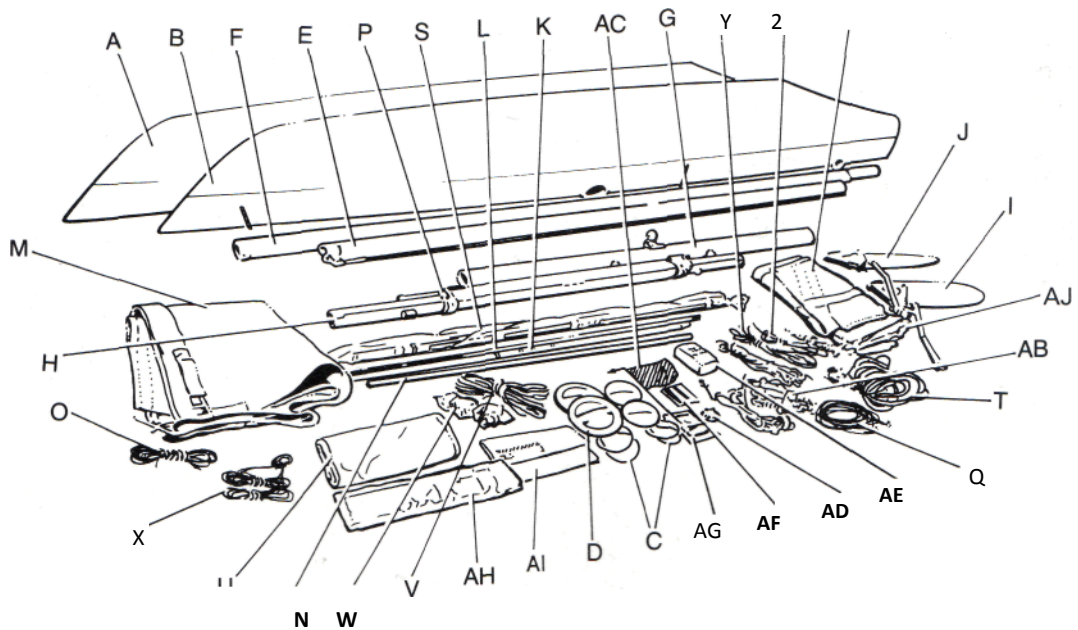

- |                                  |  |   |
|----------------------------------|--|---|
| A Port hull                      | M Trampoline   | X Jib strop and carbine hook (optional) |
| B Starboard hull                 | N Trampoline tube  | Y Main halyard                          |
| C 'O'Rings (2 large/2 small)     | O Trampoline lacing line   | Z Main sail down haul                   |
| D Hatch covers (2 large/2 small) | P Toe straps   | AB Traveller line                       |
| E Lower mast section             | Q Standing rigging: with trapeze wire (optional)<br>: jib halyard (optional) | AC Burgee                               |
| F Upper mast section             | R Mainsail   | AD Adhesive tape                        |
| G Main beam                      | S Mainsail battens(x7)   | AE Sponge                               |
| H Rear beam                      | T Main sheet   | AF Wind indicators                      |
| I Port rudder                    | U Jib (optional)   | AG Knife/shackle key                    |
| J Starboard rudder               | V Jib sheets (optional)  | AH Paddle                               |
| K Connecting bar                 | W Jib sheet blocks (optional)  | AI Instructional folder/sail numbers    |
| L Tiller extension               |  | AJ Sail bag                             |



### RIGGING YOUR SPRINT 15

Place the hulls on a flat area of ground approximately 3m apart with the trampoline track facing upper-most. See below. (If a suitable area is unavailable use 4 tyres or similar to protect your craft).

Select the main beam, Part G, check before insertion that the mast ball is facing towards the deck.

Slide the beam into the housing of one hull until the thrust pad meets the hull side, (Fig 3).

Select the rear beam, Part H. Check before insertion that the traveller track is facing towards the deck.

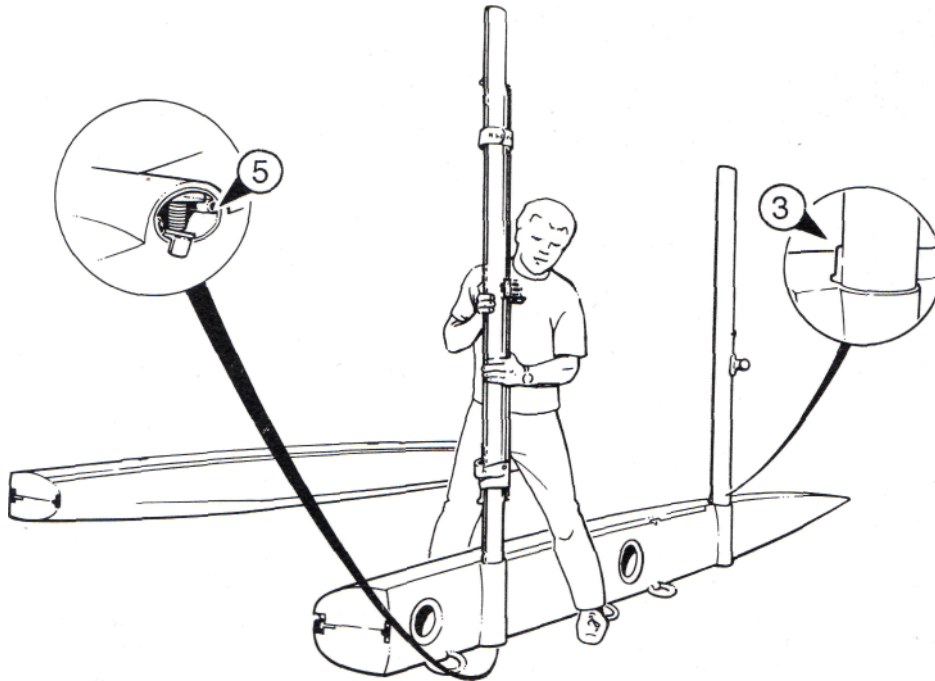

Raise the retaining clip at the beam end by pressing the spring to one side, (Fig 4). Insert the rear beam into its housing and slide home until the thrust pad meets the hull. Check that the retaining clip has dropped over the outer edge of the hull side, (Fig 5).

Carefully pull the beams down into the horizontal position. Raise the unattached hull and line up the beam housings. Slide the hull onto the beams making sure that the hull is moved in a parallel action. The hull is fully home when the thrust pads are against the inner hull side and the rear beam clip has dropped over the outer edge, (Fig 6).

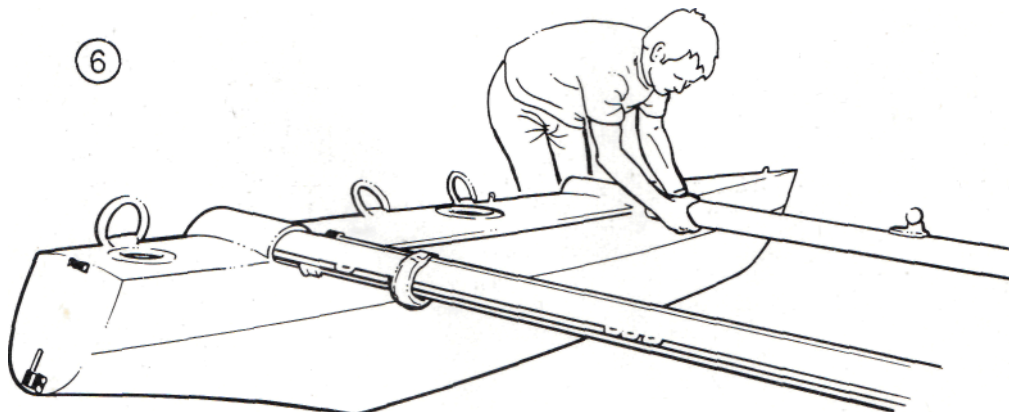
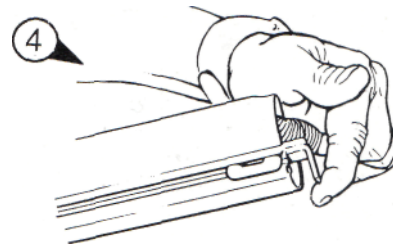

## ADDING THE TRAMPOLINE

- Identify the trampoline (Part M) and lay it between the hulls with the webbing handles facing down.
- Identify the front edge and insert the bolt rope into the main beam as shown, (Fig 7). Check that the trampoline is in the centre of the beam).

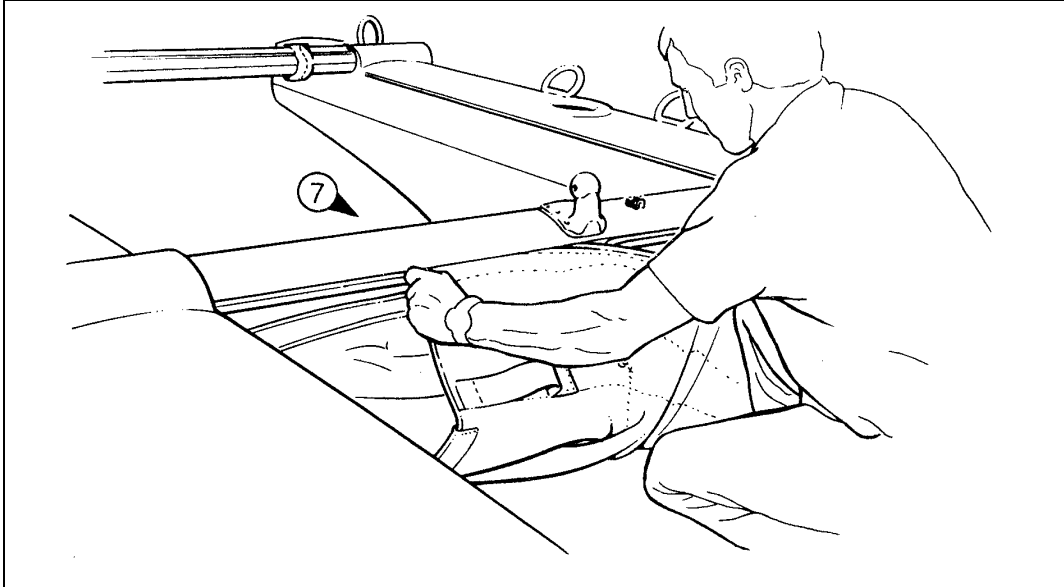

- Take the side bolt ropes and slide them into the trampoline tracks on both hulls, (Fig 8).

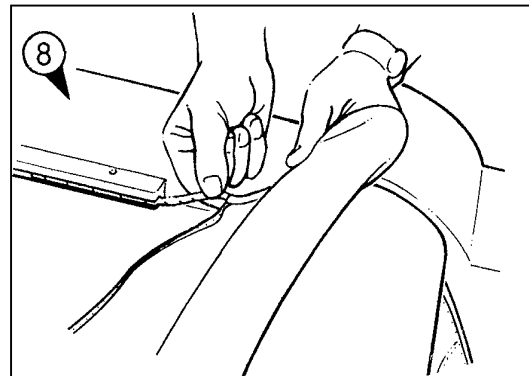

- Carefully slide the trampoline back along the tracks an equal amount until it is fully inserted in the track, (Fig 9).
- Feed the trampoline tube into the sleeve at the back of the trampoline and push the loose ends of the trampoline bolt rope into either end, (Fig 10).

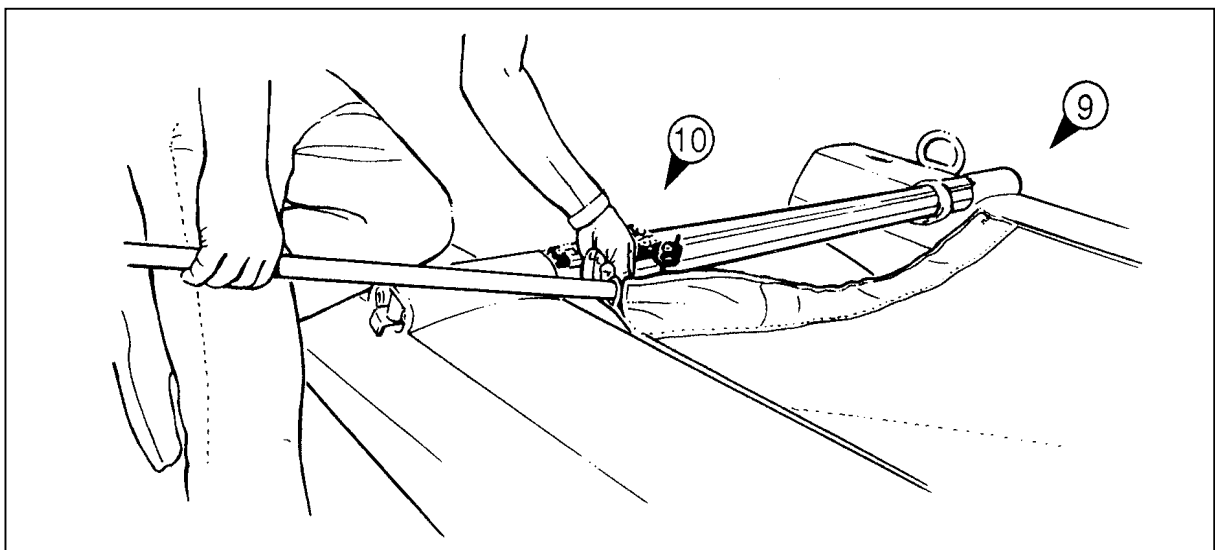

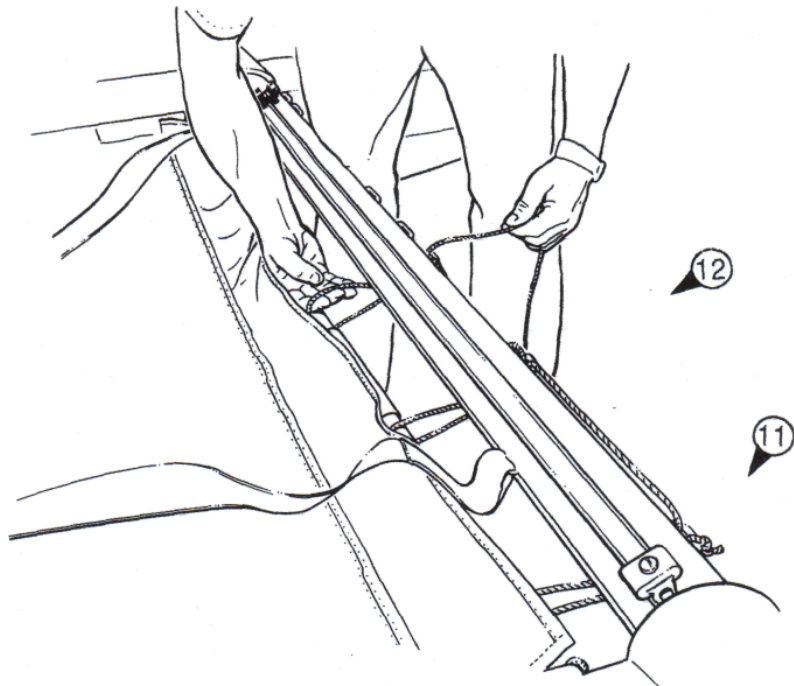

Identify the trampoline lacing line, Part O, and tie it to the outer most beam slide, (Fig 11).

- \* Lace the trampoline, (Fig 12), making sure that the slides are opposite the trampoline cut-outs and that the centre slide is not used.
- \* Tension the trampoline and secure with a suitable knot. (You may find when the trampoline is new it will need several attempts to achieve maximum tension. This is best carried out immediately after sailing, Fig 13).
- \* Identify the toe straps, Part P, and lace them to the front beam as shown, (Fig 14).

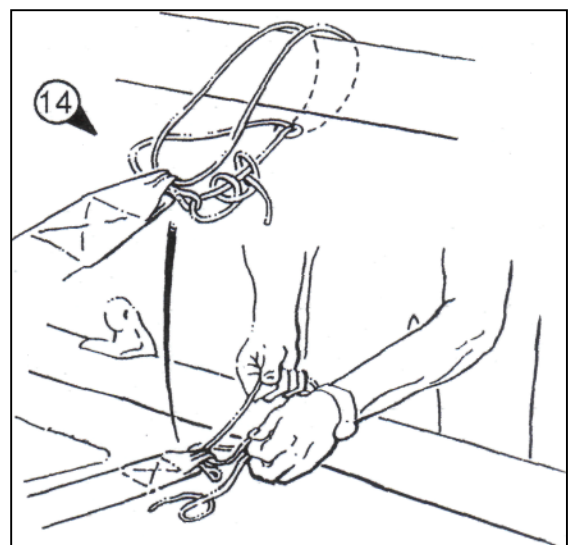
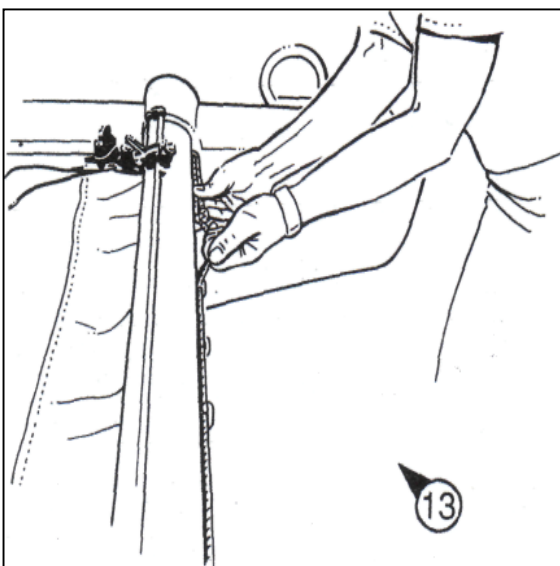



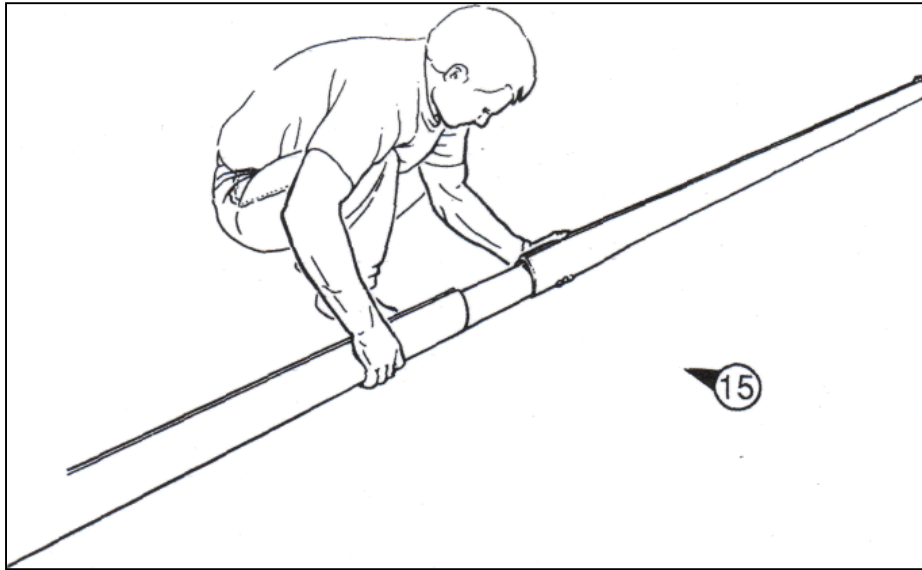

**RAISING THE MAST**

- \* Slide the two halves of the mast together, (Fig 15). (Make sure there is no grit on the mating surfaces).
- \* Identify the main halyard, Part Y and feed it into the halyard slot as shown, (Fig 16).
- \* Slide the halyard down the luff groove using a knife, or similar, and retrieve the lower end via the halyard roller finishing with a stopper knot as shown, (Fig 17).

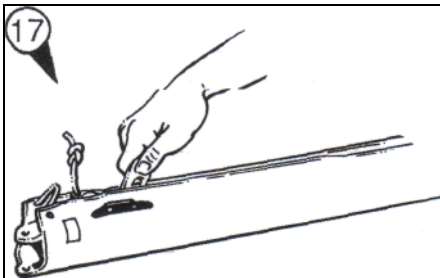
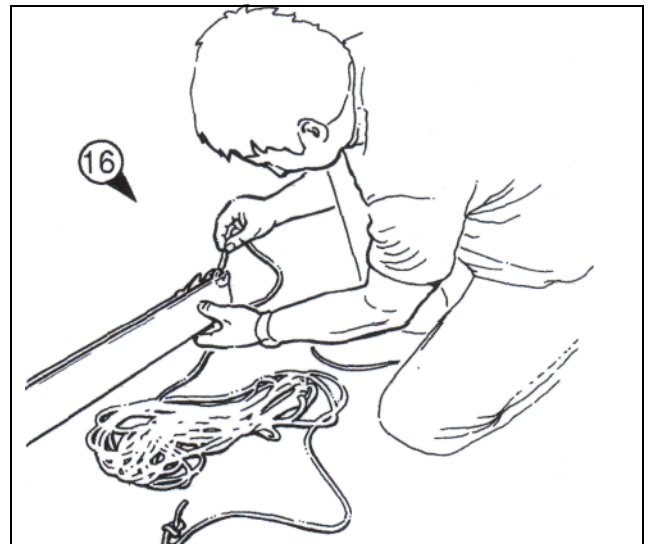

Place the mast on the mast ball facing aft and use the mast pin to secure it on the heel as shown, (Fig 18). Lay the mast carefully on the rear beam using some suitable padding ie transport packing or similar for protection.

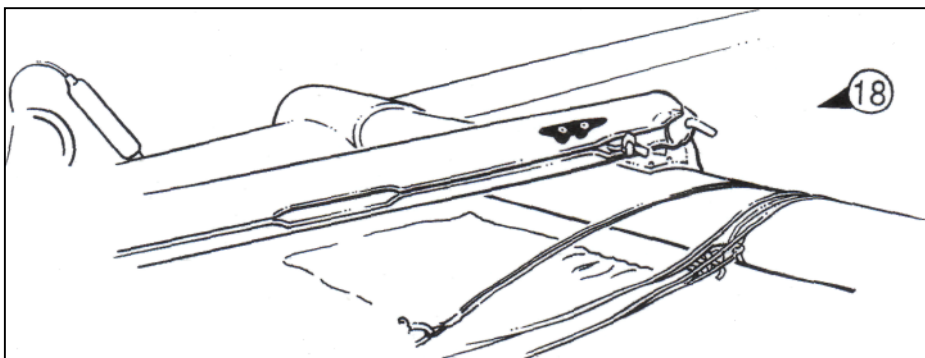

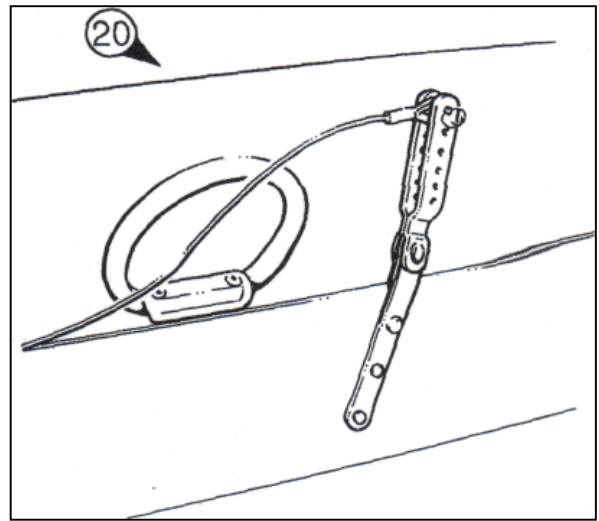
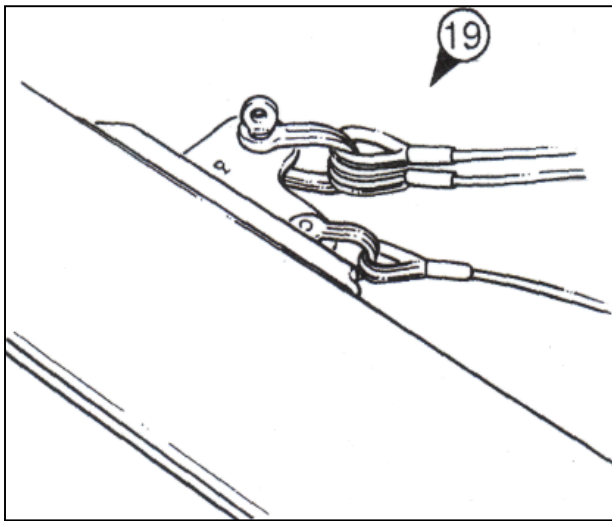

- Identify the rigging wires, Part Q, and connect the hound fitting to the mast as shown, (Fig 19). (Make sure the fitting is correct with the wine glass stamp facing towards the top of the mast).
- Carefully select the shroud wires and connect them to the shroud plates as shown, (Fig 20). The vernier shroud adjuster should be positioned on hole No 1 from the top. It is important to check there are no twists or kinks in the rigging.
- 'Raise the mast by lifting it from the stern on to your shoulder and walk forward on to the trampoline, (Fig 21). (This is easiest done when the boat is horizontal or facing slightly downhill).
- NB: Raising the mast can be done easily single-handed but if two persons are present it is helpful to have someone holding the fore-stay as extra precaution.
- Once the mast has been raised and restrained by the shroud wires the mast pin should be removed allowing the mast to rotate.
- Identify the bridle wires, (Fig 22) and secure to the tang fittings on each hull, (Fig 23). (Check that the loop of the wind wand and line for the jib roller is facing aft).

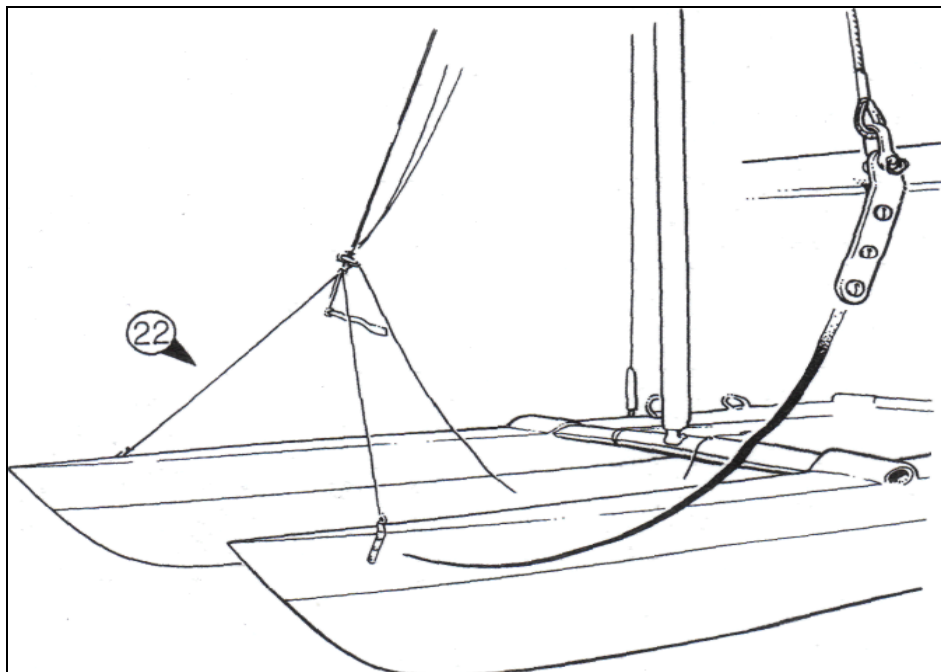
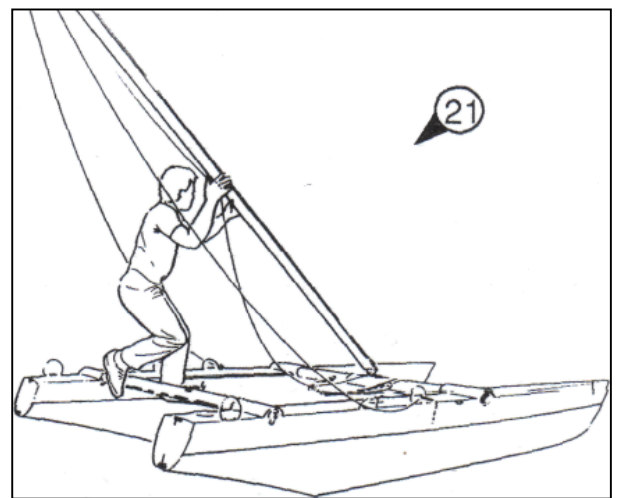

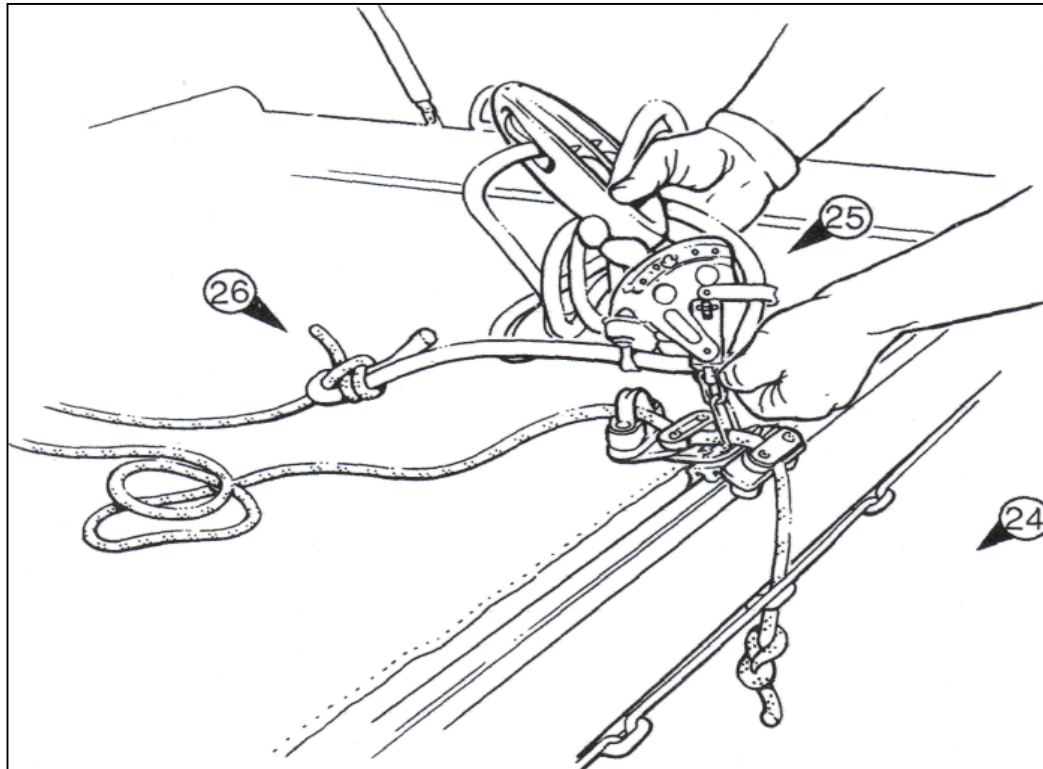

### ATTACHING THE SHEETS

- Select the traveller line, Part AB, and feed it through the traveller assembly and down through the centre slide on the rear beam as shown, (Fig ).
- Identify the main sheet assembly, Part T, and attach it to the traveller loop as shown, (Fig 25) . (It is important that the shackle eye faces aft).
- Tie the tail of the main sheet and the end of the traveller line together with a suitable knot, (Fig 26) .
- Identify the main sail downhaul, PART Z, and connect it to the mast as shown, (Fig 27) .
- Identify the downwind indicator, PART AF, and secure it to the wind wand as shown, (Fig 28)
- Tape all split rings and pins for security using the supplied tape, (Fig 29).
- Select the four 'O' rings, Part C, (2 large and 2 small) and place them around the hatch rings. Place the hatch covers, Part D, in their relevant positions and secure firmly with a screw action, (Fig 30). (Make sure the hatch covers are not cross threaded).

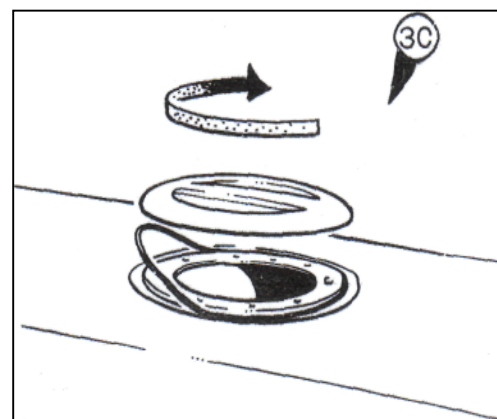
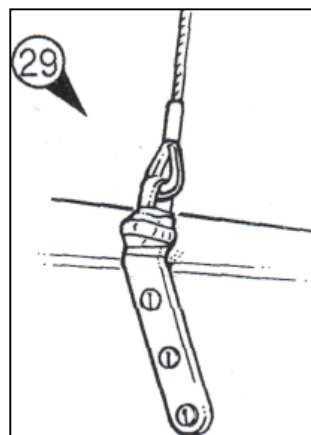
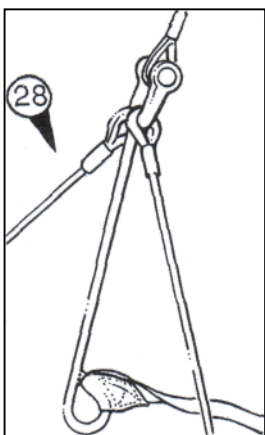
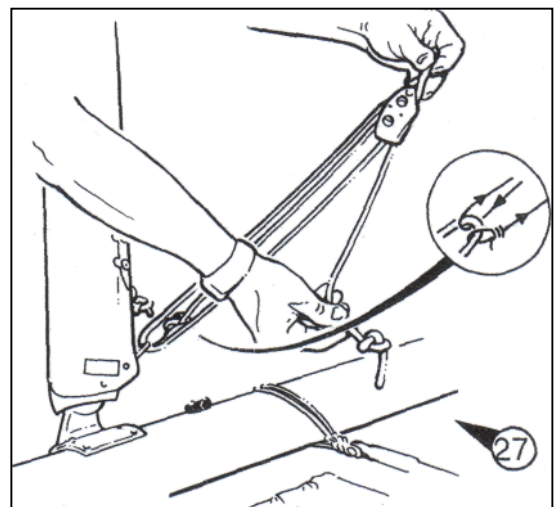

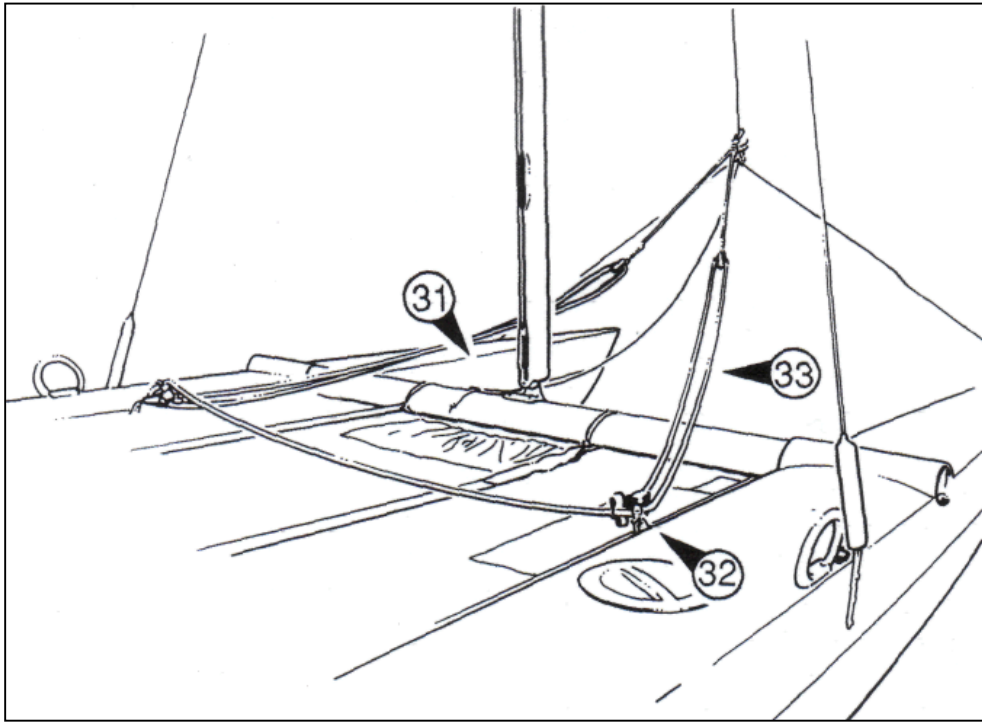

**JIB OPTION**

If your boat is fitted with jib and furler read the following. Take the line from the jib and furling drum and feed it through the jamming cleat on the main beam as show, (Fig 31). Check that the jib halyard (wire) and the slave up haul line (rope) are not twisted around the forestay. Identify the jib blocks PART W and secure them to the fairlead clips as shown, (Fig 32). Identify the jib sheets Part V and thread them through the jib sheet system and jib strop Part X as shown, (Fig 33).

**TRAPEZE WIRES OPTION**

If your boat is fitted with trapeze wires read the following: Feed the trapeze shock cord and clips through the bulls eye on each hull as shown (Fig 34). Check the trapeze wires are not twisted and secure to the trapeze shockcord via the clips as shown (Fig 35)

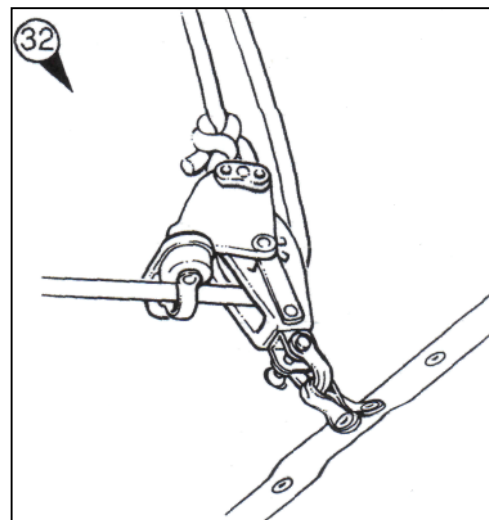
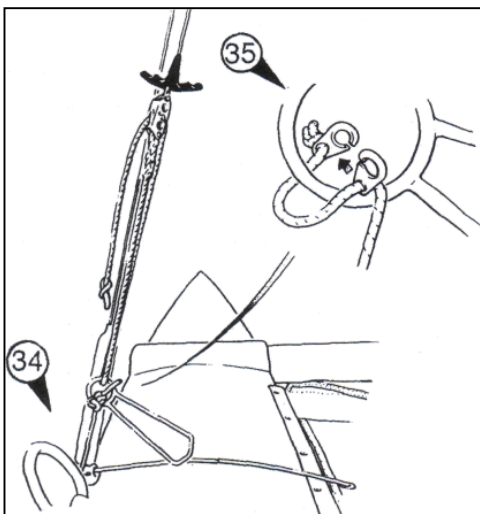

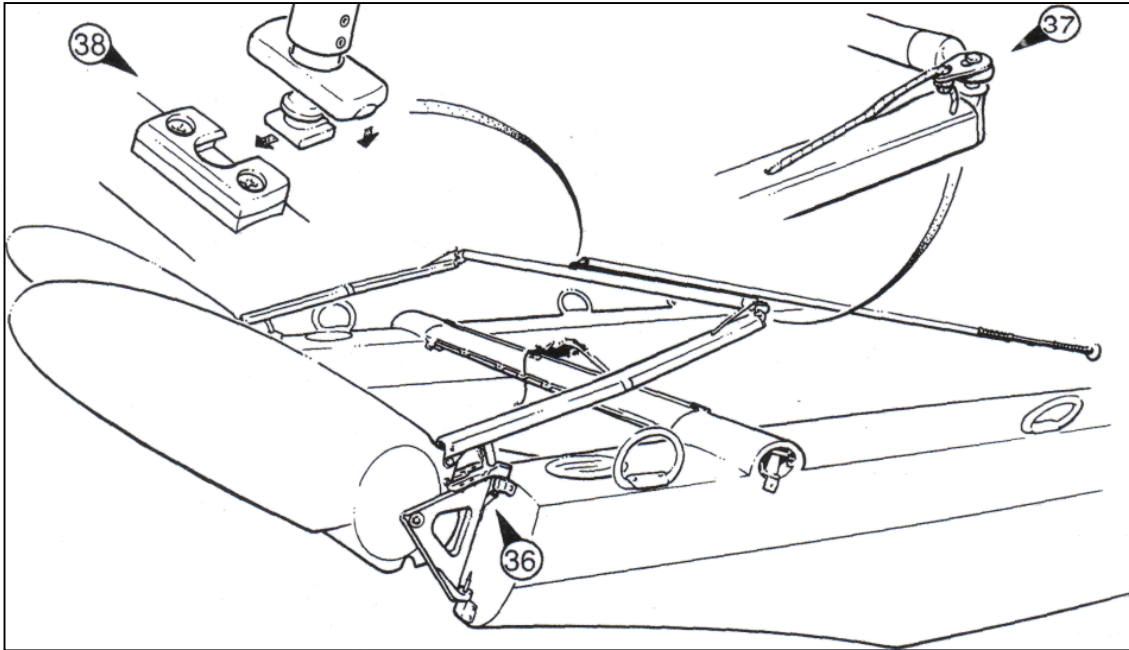

### CONNECTING THE RUDDER ASSEMBLY

- \* Identify the port and starboard rudders (left-right) and position on the hulls as shown. (Make sure the retaining clips lock correctly.) (Fig 36).
- \* Select the connecting bar, Part K, and place on the tiller pins, secure with the clip as shown, (Fig 37). (The connecting bar should be positioned with the black clip facing up.)
- \* Take the tiller extension, Part L, and clip it on to the connecting bar as shown, (Fig 38) .

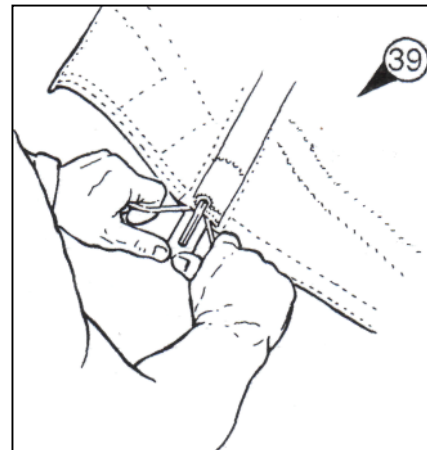

### RAISING THE SAILS

#### MAINSAIL

- \* Lay out the mainsail on a clean surface and insert the battens (No. 1: Bottom/No. 7: Top)
- Lace the batten ties through the batten and sail.  
Tension battens using the thumb and fore finger so that a **small** amount of tension is created down the batten pocket, (Fig 39). Secure the tie with a reef knot and feed the tail ends down the side of the batten as shown, (Fig 40). Roll the sail from the foot and place on the trampoline with the luff facing forward.

40

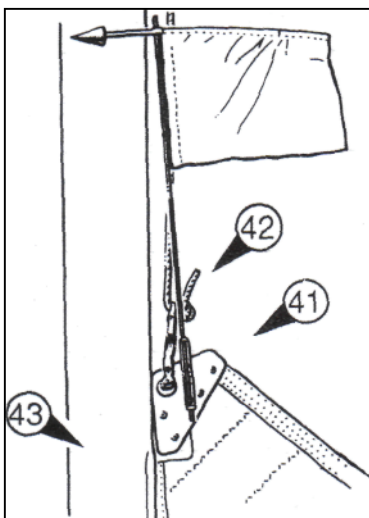
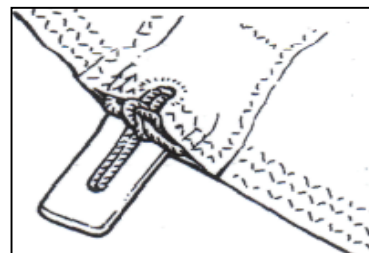

- \* Position your boat with the bow facing into the wind.
- \* Take the burgee (Flag) and clip it onto the head board as shown, (Fig 41).
- \* Attach the halyard to the head of the sail with the halyard knot facing aft as shown (Fig 42. Insert the luff of the sail into the mast groove opening approximately 0-5m above the mast base (Fig 43).



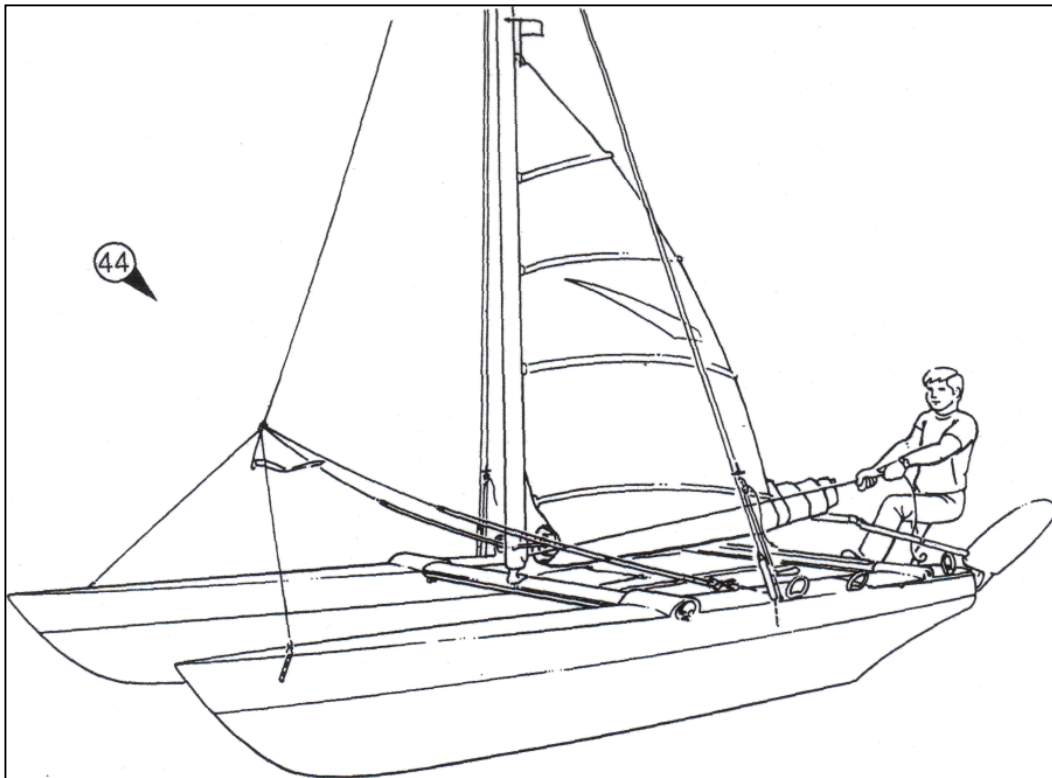

- \* Check that the halyard is running up the line of the mast groove (not around the mast hook) and raise the sail by pulling the halyard where it exists from the base of the mast, (Fig 44).
- \* The mainsail is secured at the top of the mast by the halyard lock and the last 15cms of the mainsail hoist should be achieved with a firm pull to ensure the locking ring is positioned over the hook as shown, (Fig 45) .
- \* Feed the tack of the sail down into the lower part of the luff groove and connect the main sail down haul hook to the eye as shown, (Fig 46). (At this point no tension should be applied to the luff of the sail.)
- \* Store spare halyard in trampoline pocket.
- \* The mainsheet assemble should only be connected to the clew eye-when the boat is in the water and you are about to go sailing.

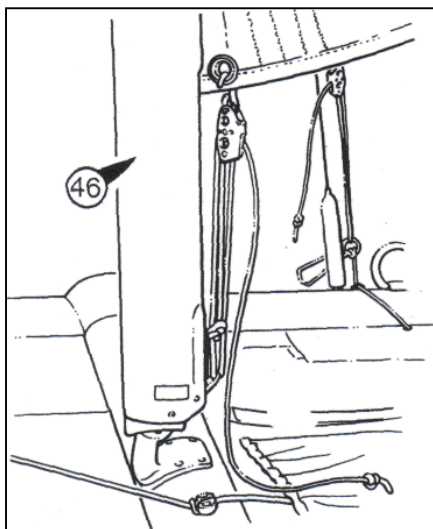
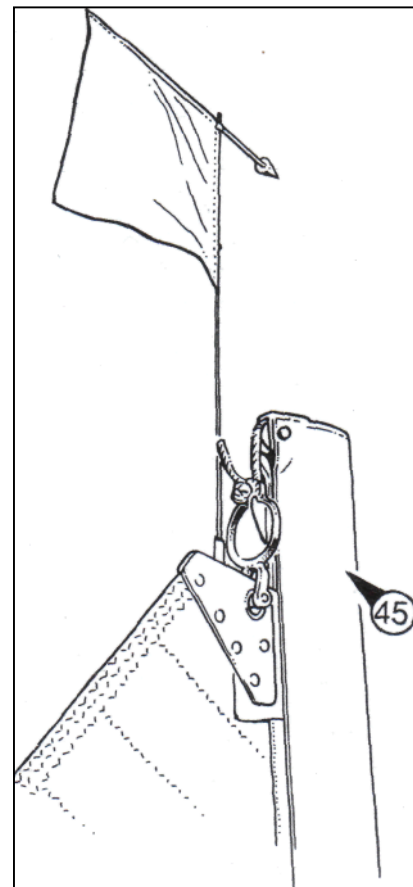

## ROLLER JIB (if fitted)

Unfurl the sail and connect the head to the wire halyard, as shown, (Fig 47). Hoist the sail via the slave halyard, clipping each sail hank to the fore-stay, using a push and turn action, (Fig 48).

When the sail is fully hoisted the slave halyard can be removed from the halyard clip and stored. The clip is then attached to the fore-stay eye as shown (Fig 49). Tension to the luff of the jib using the down haul line, as shown, (Fig 50).

Connect the jib sheet clip to the clew as shown (Fig 51).

Furl the jib by pulling the jib furling line, (Fig 52).

NB. If the jib furling drum is not loaded with the line it may be necessary to disconnect the jib stop and wind the jib around the fore-stay until fully stored. Re-connect the jib stop, the drum will now load with line when the jib is pulled out.

IMPORTANT: The jib can only be rolled or un-rolled when the mainsheet is not under tension.

\* Identify the paddle, Part AH, and place in trampoline pocket ready for use.

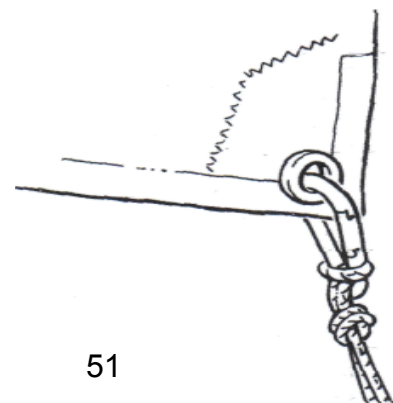
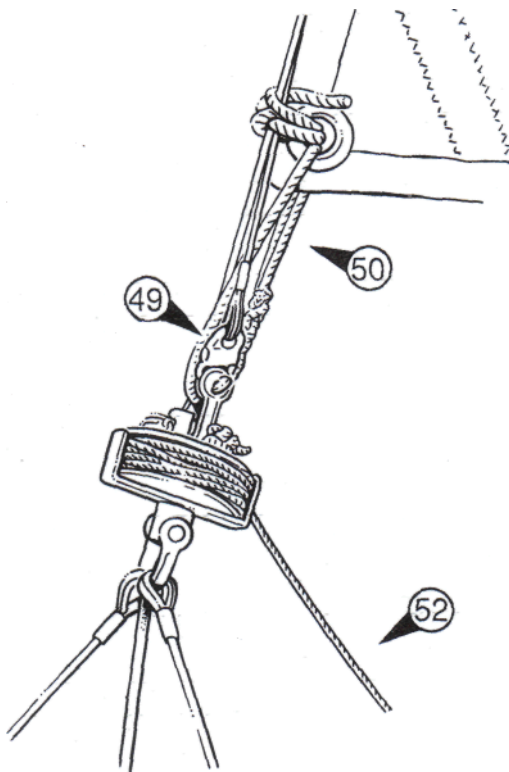
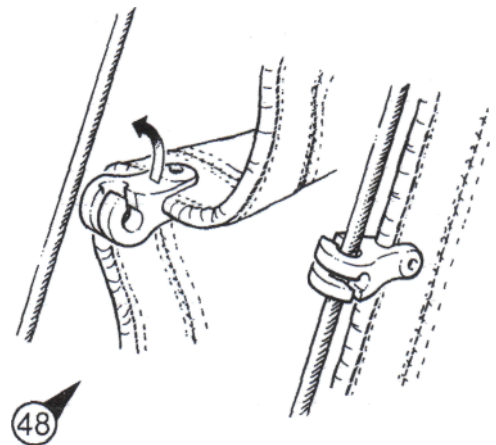

51

## YOUR FIRST SAIL

Your boat is now ready to sail but before you launch it, it is best to familiarise yourself with the boat's equipment, personal safety, and the technique of lifting and lowering the rudders.

### PERSONAL SAFETY

The Sprint 15 is an excellent compromise between fun, speed and safety. We recommend you always wear suitable clothing and adequate buoyancy aid/life jacket when venturing afloat.

### RIGHTING IN THE EVENT OF A CAPSIZE

The Sprint 15 can be righted from a total inversion or a 90 degree knockdown. The righting line is situated in the main beam as shown, (Fig 53) and should be fully extended to assist in the righting procedure.

NB. All catamarans can only be righted when the mast is pointing towards the wind.

An excellent reference book is "The Catamaran Book" by Brian Phipps.

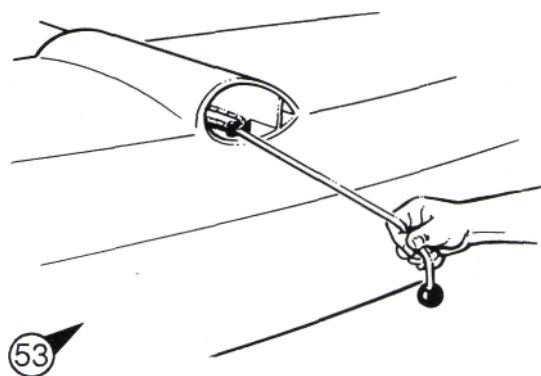

### LIFTING AND LOWERING RUDDERS

The rudders may be lowered independently. To lower a rudder, lift the tiller arm via the connecting bar and gently push backwards, (Fig 54) until the lock roller drops into the lower slot on the rudder blade. To lift the rudders, hold the connecting bar close to the tiller end. Lift and pull in a scoop action, (Fig 55) allowing the roller to follow the rudder cam into the upper rudder slot.

NB. It is a good idea to lift and lower rudders independently to ensure some steerage control whilst sailing on and off the beach.

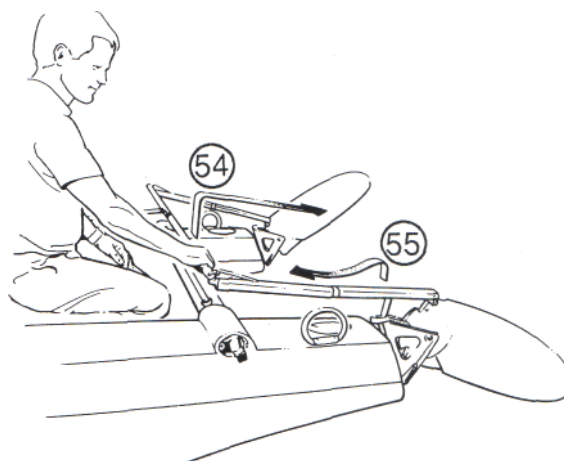

### JIB AND MAINSHEET BLOCKS

- \* All blocks can be adjusted to allow quick release of sheets from the jamming cleats, (Fig 56).
- \* The mainsheet block also has a ratchet facility for sailing in strong winds (Fig 57).

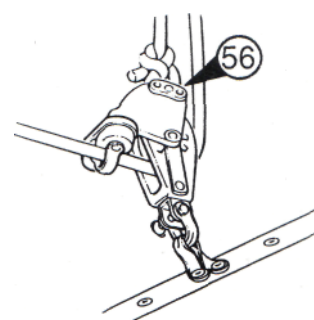

### LOWERING THE MAIN SAIL

To lower the main sail it is necessary to detach the halyard ring from the mast head lock. This sequence is simple but needs to be accurately followed.

1. Place the boat head to wind.
2. Disconnect the main sail down haul and remove the lower luff from the mast groove.
3. Pull the halyard firmly to lift the halyard ring off the hook, **retain** the tension on the **halyard**.
4. Turn the mast to port (left).
5. Release the halyard and pull the tack of the main sail downwards, (make sure the mast is still rotated to port).
6. Once the sail has been pulled down past the hook, the mast can be released and the sail lowered in a normal fashion.
7. It is a good idea to roll the sail as it is lowered to prevent it from being blown away in the wind.

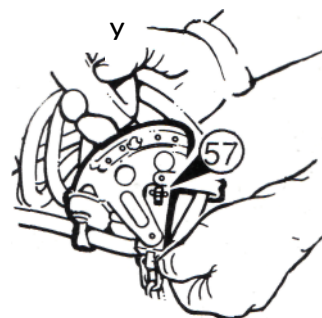

## ACCESSORIES

### 1. JIB ACCESSORY

If your boat was supplied without the jib accessory, you will need to replace and add to certain parts of the boat's equipment. Identify all parts of the Jib Accessory Option.

A Jib	G Jib sheet
B Forestay strop	H Jib strop
C Forestay	I Carbine hook
D Furling drum	J Single block x 2
E Jib block x 2	K Jib halyard plus Slave halyard
F Fairleadhookx2	L Rivet plugs
	M Various fixings

#### Tools required for fitting Jib Option.

Drill, drill bits, rivet gun, pliers/shackle key, extension rule.

#### FITTING INSTRUCTIONS

Attach all accessory jib fittings to hull and main beam as shown on drawing.

NB. All rivet holes should be sealed with supplied rivet plugs.

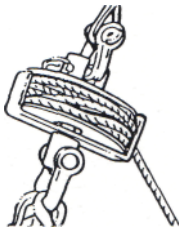

Replace the standard fore-stay with the assembled roller reefing system.

Attach the roller drum to the wind indicator as shown.

NB. Make sure the rope guide faces towards the main beam, as shown.

### 2. TRAPEZE OPTION

If your craft was not fitted with the trapeze option when ordered, please follow the following instructions.

Identify all parts for Trapeze Option.

A Trapeze wires x 2
B Trapeze shockcord
C Black bullseye Fairlead x 2
D Englefield clips x 4
E Various fittings
F Rivet plugs

Tools required for fitting Trapeze Option

Drill, drill bits, rivet gun, pliers/shackle key, extension rule.

#### FITTING INSTRUCTIONS

Attach all accessory trapeze fittings to hull as shown on drawings.

NB. All rivets should be sealed using rivet plugs supplied.

#### RIGGING INSTRUCTIONS

Attach the trapeze wires to the large shackle at the hound fitting as shown, (Fig 59).

Feed the trapeze shock cord across the boat as shown (Fig 60). Four Englefield clips should be attached to the shockcord as shown (Fig 61).

Please follow the rigging instructions.

### 3. LAUNCHING TROLLEY

The launching trolley can be transported assembled or broken down (two simple bolts secure the cup to the main shaft). To position the trolley under the hulls, place the trolley across the bows and lift the bows to allow the trolley room to slide under the keels. Its final position should be at the boat's balance point which is approximately in line with the shroud plates.

NB It is inadvisable to leave the boat in this position for any length of time as it can easily be blown off the trolley given sufficient wind.

### 4. ROAD TRAILER

The standard road trailer available for the Sprint 15 allows you to tow your catamaran fully made up. Once the mast has been lowered, the hulls can be slid onto the trailer (bow first) and the lighting board/mast support clipped onto the rudder fittings. The hulls and mast should then be secured with suitable line.

NB Before towing your trailer you should check that the weight on the tow hitch is acceptable and that the position of the hulls are such that they cannot catch the side of the towing vehicle when turning. The trailer has facility for adjustment if required.

### 5. BOAT AND HULL COVERS

These are available for all Dart catamarans. Their use will help protect your craft and prolong its quality finish.

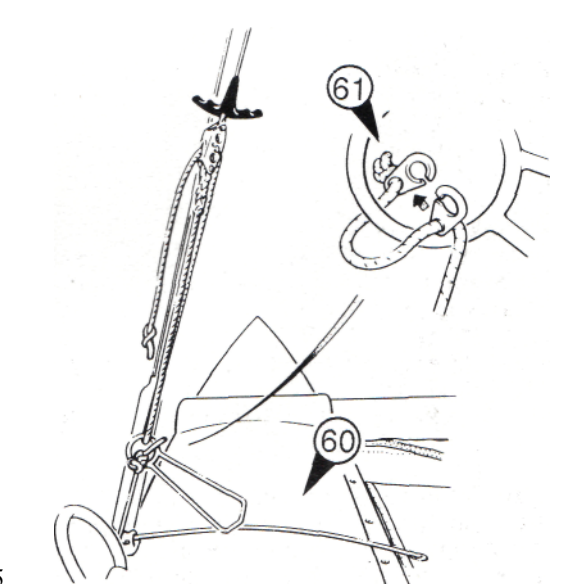
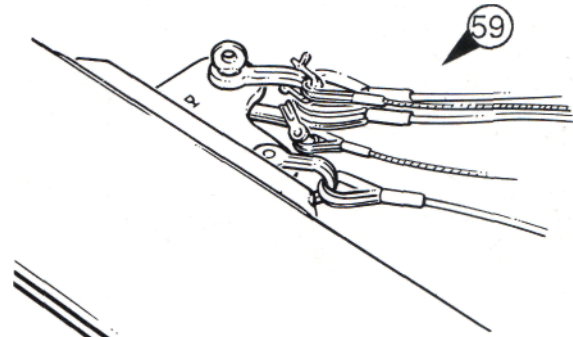

## GENERAL MAINTENANCE OF YOUR SPRINT 15

### WEEKLY

1. Your boat should always be tied down securely to ground fittings when not in use. Sails should be stored dry when possible.
2. Any water that has accumulated in the hull during sailing should be removed using the applied sponge.

### MONTHLY

1. Ropes and rigging should be checked periodically for wear or damage.
2. All moving parts such as jamming cleats and blocks should be lubricated lightly with WD40 or similar.  
NB This includes the lifting mechanism for the rudder system but not the roller itself.
3. It is important that you regularly check that shackle fixings are secure at the hound fitting and that all clevis pins and rings are securely taped.

### GEL-COAT REPAIR

Should you damage the gel-coat surface of your boat, you should repair it as soon as possible. The correct gel-coat colour can be ordered through [www.catparts.windsport.co.uk](http://www.catparts.windsport.co.uk)

1. Sand back the damaged or flaking gel-coat until a solid area is produced. Make sure the area is clean and there are no sharp edges, (Fig 62).
2. Mix the gel-coat with approximately 2% of hardener and apply using a fine artist brush or similar, (Fig 63). Cover the area with cellophane and allow to dry, (Fig 64).
3. Brushes and equipment should be washed out in acetone if required.
4. When dry, carefully remove cellophane and sand surface with wet and dry sand paper until it blends in with the original area, (Fig 65).
5. Finally polish the area using a fibre glass rubbing compound or similar.

NB If substantial damage is sustained to your craft, you should take advice, call Windsport on 01326 376191 or email Windsport on [info@windsport.co.uk](mailto:info@windsport.co.uk). All spares for your Sprint 15 can be found online at [www.catparts.windsport.co.uk](http://www.catparts.windsport.co.uk)

62

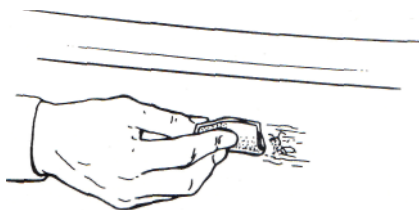

64

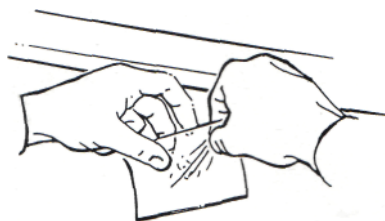

63



65

